

PROGRAMMABLE PANEL MOUNTED TAP SENSOR

The Panel Mounted Programmable Tap Sensor is available in brushed stainless steel. Adjustable settings include; run-on time, sensor range, purge and more. You will need to purchase a hand held programmer to adjust settings by yourself on site.

Simply put your hand within the sensing range to activate the water. As long as the sensor detects your hand the water will continue to run. Take your hand away and the water will stop after the overrun time that you have programmed.

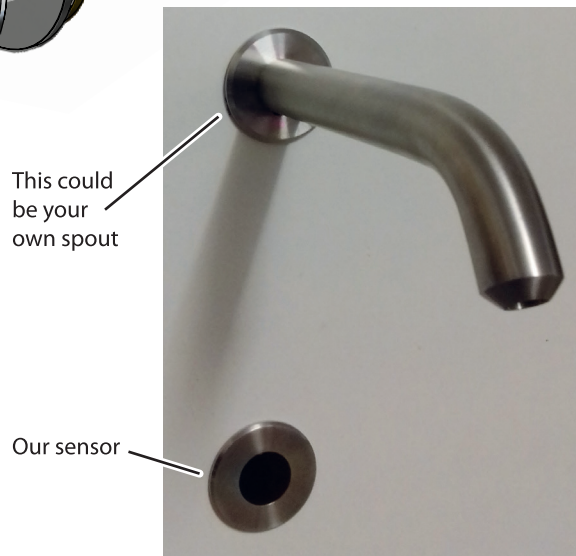

Tap Sensor Kit Order Codes:

PsensT-B

Battery powered tap sensor kit

Kit c/w

1 x Programmable Sensor
1 x Pre-wired 15mm Solenoid Valve
1 x Pre-wired Battery Pack

PsensT-M

Mains powered tap sensor kit

Kit c/w

1 x Programmable Sensor
1 x Pre-wired 15mm Solenoid Valve
1 x Pre-wired 6V PSU

For applications that require separate hot and cold supplies per basin please use special colour coded sensors

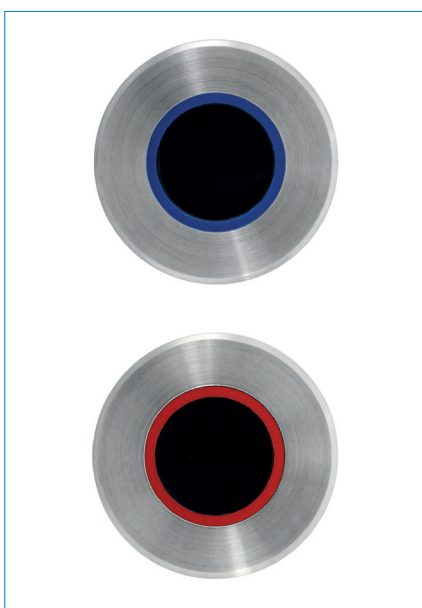

Battery Powered Kits

Blue Insert (Cold) Tap Sensor Kit Order Codes:

PsensT(B)-B

Battery powered tap sensor kit

Kit c/w: 1 x Programmable Sensor
1 x Pre-wired 15mm Solenoid Valve
1 x Pre-wired Battery Pack

Red Insert (Hot) Tap Sensor Kit Order Codes:

PsensT(R)-B

Battery powered tap sensor kit

Kit c/w: 1 x Programmable Sensor
1 x Pre-wired 15mm Solenoid Valve
1 x Pre-wired Battery Pack

Mains Powered 2 Tap Kit

Red + Blue Inserts 2 Tap Sensor Kit Order Code:

PsensT(R+B)-M / 2 Tap Kit

Mains powered tap sensor kit

Kit c/w: 2 x Programmable Sensors
2 x Pre-wired 15mm Solenoid Valves
1 x Pre-wired 6V PSU
1 x T-Connector

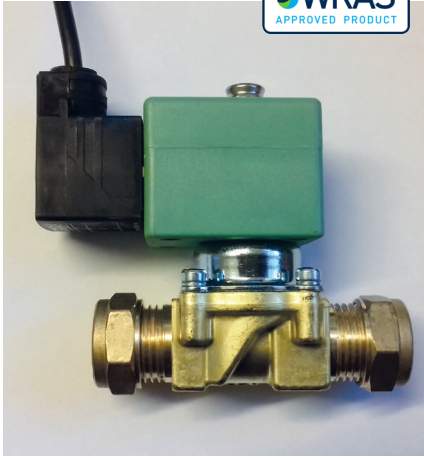

Standard pre-wired 15mm G202 solenoid valve for water pressure 0.75 bar - 10 bar.
Optional low pressure valves also available on request.



Hand Held Programmer

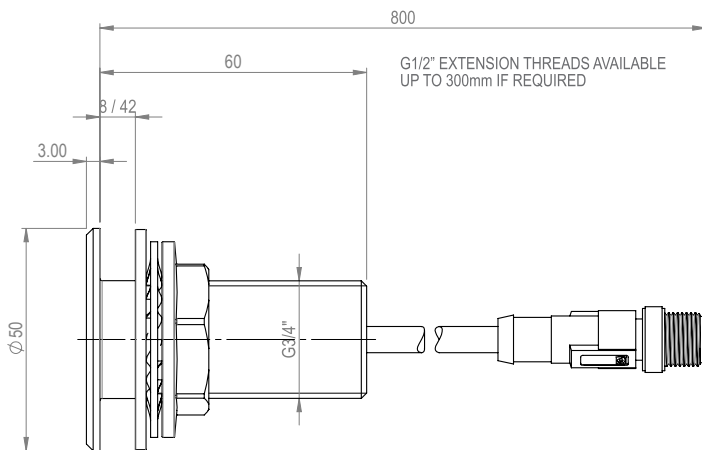

Technical Data:

Cut-out hole	Panel mounted (Ø28mm drill hole required).
Sensing Range	Programmable from settings 1 – 10.
Overrun time	This is the time the water will continue to flow after you take your hands away from the sensor. Programmable from: 2, 5, 10, 15, 20 & 30 seconds.
Wave-on/Wave-off	Normally OFF. When switched ON this allows you to override the standard overrun time by putting your hand in front of the sensor for a second time (if you don't, the water will still turn off after the pre-set but adjustable overrun time).
Anti-vandal time	This is automatic water turn-off time in case someone puts e.g. chewing gum over the sensor to try and keep the tap running constantly. Programmable from: 30 secs, 1, 2, 4 & 8 minutes.
Automatic purge	When purge is programmed ON, if a tap has not been used for a certain period of time it will automatically turn itself on to purge itself to help prevent water dead legs. Tap non use times before purge is activated from any of: 3, 6, 12, 24, 36 & 48 hours. Programmable water on time per purge from: 30 seconds, 1, 2, 4, & 8 minutes.
Lock-out	Normally OFF. When set ON this allows the system to lock out if tap sensor has been activated from any of 4, 6, 8 & 10 operations in a single 15 minute period. The lock out period is 15 minutes and the system will automatically re-set itself once the lock out period has elapsed.



ROBERT PEARSON & COMPANY LTD

Post Office House, Post Office Lane
Stockton, Warminster
Wiltshire BA12 0SE

Telephone: (01985) 850954
Facsimile: (01985) 850112

E-Mail: sales@robertpearson.co.uk
Website: www.robertpearson.co.uk