



THERMOSTATIC MIXING VALVES



Delivers safe, blended hot water to taps, bidets and other water outlets

These 15mm and 22mm thermostatic mixing valves are designed primarily for single outlet use. They deliver safe, blended hot water to taps, showers, bidets and other water outlets making them ideal for use in hospitals, schools and leisure centres. The element that controls the temperature of the mixed water discharging from the valve works proportionally on both hot and cold water supplies in order to maintain the temperature of the mixed water discharged.



The thermostatic mixing valve has been independently tested and approved by the TMV3 scheme as a type 3 valve under the requirements of the NHS MES - D08 and approved by Buildcert as meeting the requirements of the TMV2 scheme. It has been specifically designed and manufactured to meet the general requirements of:

- National Health Service Model Engineering Specification: Thermostatic Mixing Valves—Health Premises - D08 and BS 7942: 2000 Thermostatic Mixing Valve for use in care establishments (TMV3)
- BS EN 1111 : 1999 Sanitary Tapware. Thermostatic Mixing Valves (PN10) General technical specification & BS EN 1287 : 1999 Sanitary Tapware. Low Pressure Thermostatic Mixing Valves General technical specification (TMV2)

Code [†]	Pressure range	Designation
HP-B	High Pressure	Bidet
HP-S	High Pressure	Shower
HP-W	High Pressure	Wash Hand Basin
LP-B	Low Pressure	Bidet
LP-S	Low Pressure	Shower
LP-W	Low Pressure	Wash Hand Basin
HP-T44	High Pressure	Bath (Unassisted Bathing)*
HP-T46	High Pressure	Bath (Assisted Bathing)*

* 22mm model only.

[†] TMV3 approval codes for all these applications. **Not** our Product Codes.

Benefits

- One valve to suit all applications
- One piece cartridge construction for ease of maintenance and replacement
- High flow rates with low pressure drops
- 15mm and 22mm versions available
- TMV3 approved—complies with NHS Estate D08 & BS7942 : 2000
- TMV2 approved—complies with BSEN1111 & BSEN1287 : 1999
- Building Regulations Part G compliant
- Robust and reliable
- Easy installation
- Integral check valves and strainers
- Available with isolation ball valves and test ports
- WRAS approved
- Highly resistant to scaling
- Anti tamper proof head

THERMOSTATIC MIXING VALVES (Cont.)

Product range and technical data

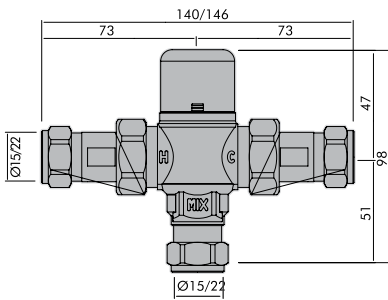

Order Code:
RP/TMV3/15



Order Code:
RP/TMV3/22

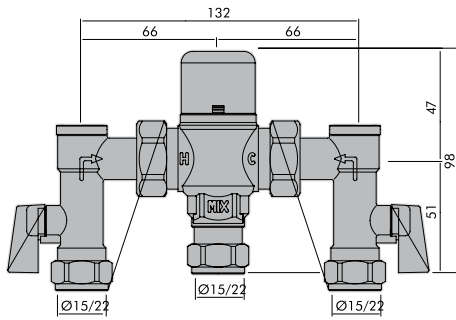

Order Code:
RP/TMV3/MX/15



Order Code:
RP/TMV3/MX/22

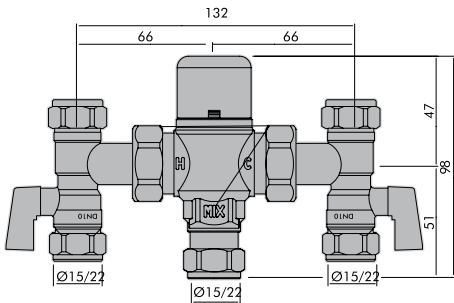

Product Range

Description	Product Code
15mm TMV3	RP/TMV3/15
22mm TMV3	RP/TMV3/22
15mm c/w MX service valve	RP/TMV3/MX/15
22mm c/w MX service valve	RP/TMV3/MX/22
15mm c/w 2 MX valves with compression top connector	RP/TMV3/MS/15
22mm c/w 2 MX valves with compression top connector	RP/TMV3/MS/22
15mm c/w 2 MX valves with test point	RP/TMV3/MZ/15
22mm c/w 2 MX valves with test point	RP/TMV3/MZ/22

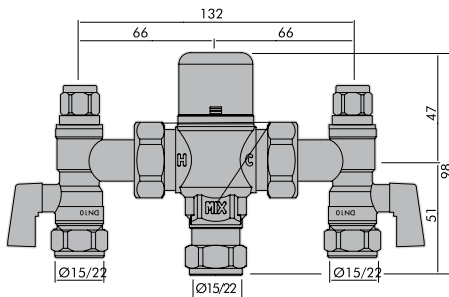

Technical Data

Temperature Adjustment Range	30°C – 50°C
Temperature Stability	±2°C
Maximum Inlet Temperature	85°C
Maximum Working Pressure	10 Bar : Static
Minimum Working Pressure	0.2 Bar : Dynamic
Inlet Temperature Range	Hot: 52–65°C; Cold: 5–20°C
D08 Working Pressure Ranges	LP: 0.2–1.0 bar; HP: 1.0–5.0 bar
Max Temp. Differential (Mix to Hot) for fail safe	10°C
Maximum Pressure Inlet Differential	5 : 1

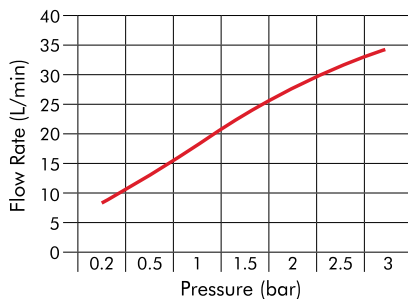

ROBERT PEARSON & COMPANY LTD

Post Office House, Post Office Lane
Stockton, Warminster
Wiltshire BA12 0SE

Telephone: (01985) 850954
Facsimile: (01985) 850112

E-Mail: sales@robertpearson.co.uk
Website: www.robertpearson.co.uk