

PDLM & PDLB Model Ceiling Recessed PIR Urinal Flushvalve Kit | Ø80mm

Water saving of up to 90%

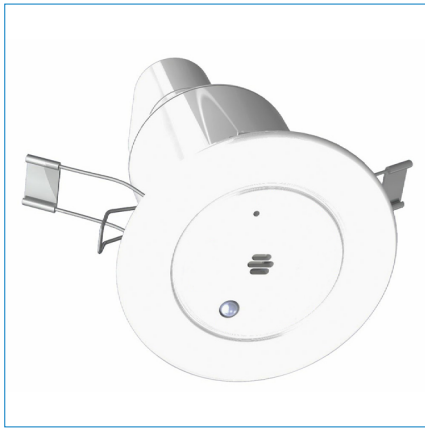

Order Codes:

PDLM Mains powered kit

PDLB Battery powered kit

Dimensions:

Ø80mm × 80mm (D)

Each kit c/w:

WRAS approved 15mm solenoid valve

PIR sensor & adjustable time controls

Battery powered units come with long life battery pack

Mains powered units come with separate transformer unit (to be wired to 3A fused spur)

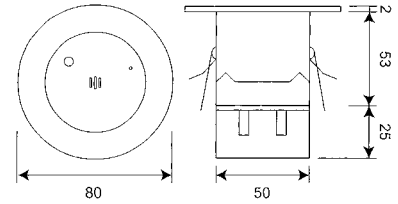

Solenoid Valve for controlled "reduced splash" filling of urinal cistern

For mains & battery powered kits

Standard 15mm (2mm Orifice) Valve to fit on an inlet pipe to a single cistern as standard

You will need to provide length of 2 core cable from valve to PIR sensor

ORDER CODE

15mm 6vDC (2mm Orifice) Valve

TECHNICAL DATA

Material Brass
 O-ring/washers..... NBR (Nitrile)
 Pressure rating 0 Bar – 10 Bar max.
 Orifice 2mm
 Connection 15mm compression
 Voltage 6vDC
 Power 6W
 Operation type Latching

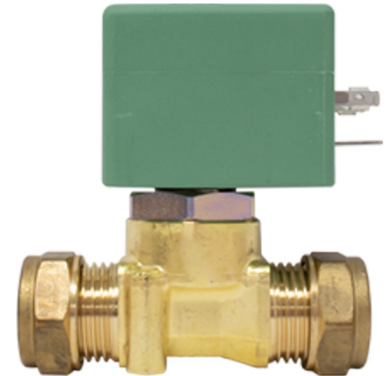
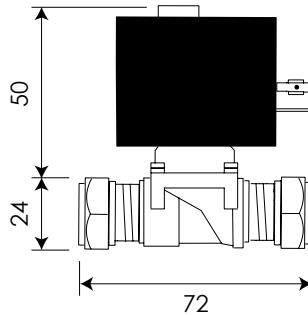

Not using a cistern?

If you are not using a cistern please call to discuss options for a larger sized orifice solenoid valve, flow regulating solutions for balancing the flow rate to each urinal bowl and backflow prevention etc.

Controlling more than one cistern?

If you need a PIR Urinal Flushvalve kit to control more than one cistern please call to discuss options for a larger sized orifice solenoid valve etc.



ROBERT PEARSON & COMPANY LTD

Post Office House, Post Office Lane
 Stockton, Warminster
 Wiltshire BA12 0SE

Telephone: (01985) 850954

Facsimile: (01985) 850112

E-Mail: sales@robertpearson.co.uk

Website: www.robertpearson.co.uk