

TAP SENSOR CONTROLS

"No touch" hygienic sensor operation

Simply put your hand within 50mm of the sensor to turn water on. Turns water off automatically after use

You can choose your own tap spout or one of ours. Sensor is fitted remotely.

TPTS model black Tap Sensor kits

Other RAL colours available



Mains-powered

water pressure 0.5 Bar – 6 Bar

Order Code:

TPTS-M/HP/MB3/1 Tap Sensor kit

- 1 no. Mains-powered tap control box
- 1 no. 15mm Plastic 12V solenoid valve
- 1 no. Sensor c/w 38mm black bezel

Order Code:

TPTS-M/HP/MB3/2 Tap Sensor kit

- 1 no. Mains-powered tap control box
- 2 no. 15mm Plastic 12V solenoid valve
- 2 no. Sensor c/w 38mm black bezel

Battery-powered

water pressure 0.75 Bar – 10 Bar

Order Code:

TPTS-B/HP/MB3/1 Tap Sensor kit

- 1 no. Battery-powered tap control box
- 1 no. 15mm G202 6V solenoid valve
- 1 no. Sensor c/w 38mm black bezel

Order Code:

TPTS-B/HP/MB3/2 Tap Sensor kit

- 1 no. Battery-powered tap control box
- 2 no. 15mm G202 6V solenoid valve
- 2 no. Sensor c/w 38mm black bezel

BLACK TAP SPOUTS

Use our remote TPTS model Black Tap Sensor Kits to control the water flow to these spouts.

Black panel mounted spout with integral 3.8 Lpm flow regulator

Other RAL colours available



Order Code: **MB3TS-PM**

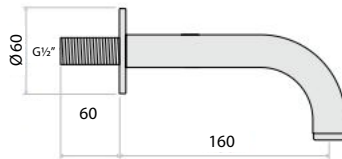

- Operating pressure **5 Bar maximum**
- Max Inlet temp **65 °C**
- Finish **Powder coated**
- Standard flow reg. **3.8 Lpm**
- Optional flow reg. **1.9, 5, 6 or 8 Lpm**

Optional unrestricted insert for very low water applications on request



Typical installation: Black panel mounted spout with our TPTS model black tap sensor (ordered separately)

Black deck/basin mounted spout c/w integral 3.8 Lpm flow regulator

Other RAL colours available



Order Code: **MB3TS-DM**

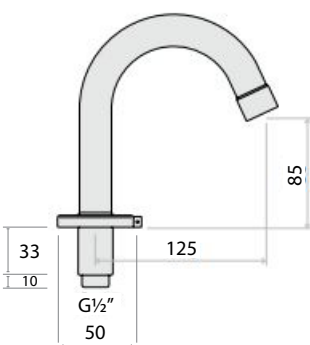

- Operating pressure **5 Bar maximum**
- Max Inlet temp **65 °C**
- Finish **Powder coated**
- Standard flow reg. **3.8 Lpm**
- Optional flow reg. **1.9, 5, 6 or 8 Lpm**



Typical installation: Black deck/basin mounted spout with our TPTS model black tap sensor (ordered separately)

TAP SENSOR CONTROL KITS—TECHNICAL

Anti-Ligature & Vandal Resistant: Ideal for custodial/mental health/public & commercial applications.

Optional Purge Facility: Available on both mains- and battery-powered kits, "Purge Facility" allows you to set the tap to come on automatically if it has not been normally operated for more than a 24 hour period (to help prevent dead legs).

Optional Lock-Out Facility: Available on mains-powered kits only, "Lock-Out Facility" ensures the tap will stop working if it has been operated more than 4 times in 15 minutes (will automatically re-set itself after 15 minutes).

You can also set the system so you can activate the sensor once to turn the water on and then activate the sensor again to override the pre-set time and turn the water off immediately. It is possible to use 1 No. sensor to control 2 No. solenoid valves using a single control box.

If you require a longer sensing range (e.g. set to the length of the tap spout) or would like the sensor mounted directly below the tap spout you can choose our brushed stainless steel Programmable Tap Sensors with plain, blue or red inserts (to denote water temperature).

Control Box

Standard tap control box with adjustable valve open time from 6 seconds to 20 seconds. *Call to discuss* for options if you require a longer valve open time.

Mains powered: You need to provide a 3 amp fused spur.

Battery powered

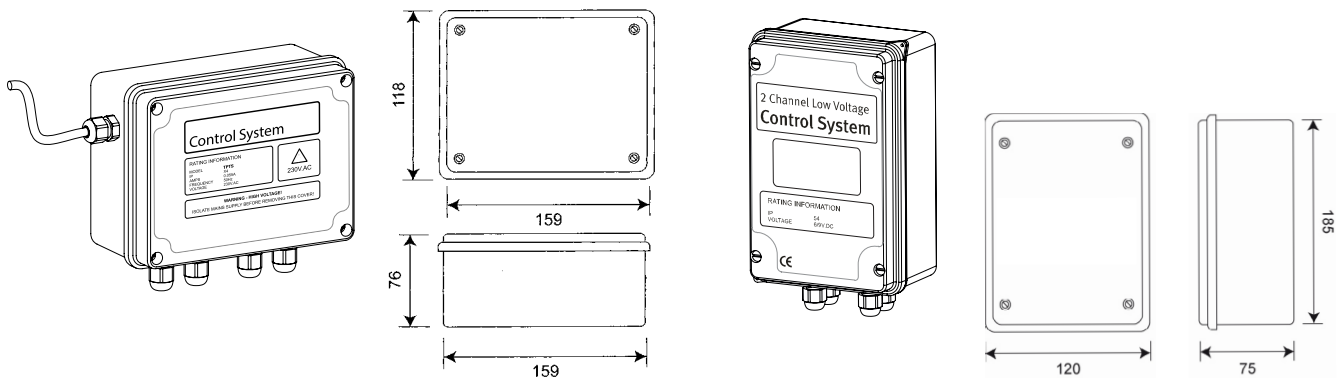

Sensor / Touchpad Switch

Ensure no bright lights (or reflected lights) are shining directly into sensor. If fitting sensor/touchpad through a thick (e.g. brick) wall, we can supply extension threads. Standard pre-wired sensor c/w 3m cable. Longer cable lengths available. *Call to discuss.*

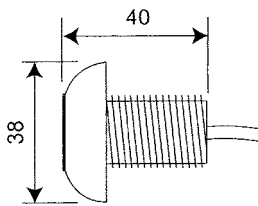

STANDARD 38mm SENSOR

- Bezel diameter Ø38mm
- Overall length 40mm
- Thread length 33mm
- Thread material ABS Plastic
- Pre-wired YES
- Cable length 3m standard
- Finishes RAL Matt Black 3
Chrome
Brushed Steel
- Insert colour N/A



WRAS approved Solenoid Valves

Please specify correct solenoid valves for your site conditions: for low pressure solenoid valves replace "HP" with "LP" in order codes. Very low pressure solenoid valves are only available for battery powered kits. Replace "HP" with "VLP" in order codes.

For mains powered kits Standard high pressure (HP) 0.5 Bar – 6 Bar

12v nylon pre-wired 15mm solenoid valve for mains powered kits.

Working Temperature Range 0°C to 60°C
Electrical connection: Spade connectors / 2-core Ø0.5mm copper cable

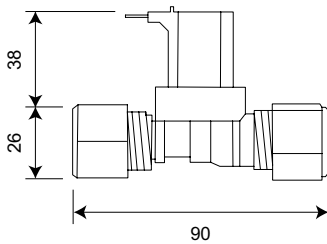

ORDER CODE
15mm 12v Plastic HP Valve

TECHNICAL DATA

Gross weight 0.215 kg
Material Nylon
Seal Material NBR (Nitrile)
Voltage 12vDC
Power 3W
Connection 15mm compression
Pressure rating 0.5 Bar – 6 Bar
Operation type Normally closed
Cable length 3m

For mains powered kits Optional low pressure (LP) 0 Bar – 0.5 Bar maximum

12v (7.1mm orifice) solenoid valve for mains powered kits.

You will need to provide length of 2 core cable from valve to control box.

ORDER CODE
15mm 12v (7.1mm) Valve

TECHNICAL DATA

Material ABS/Brass
O-ring/washers..... Nitrile
Pressure rating 0 Bar – 0.5 Bar max.
Orifice 7.1mm
Connection 15mm compression
Voltage 12vDC
Operation type Normally closed

For battery powered kits Standard high pressure (HP) 0.75 Bar – 10 Bar

6v non-wired G202 solenoid valve for battery powered kits.

You will need to provide length of 2 core cable from valve to control box.

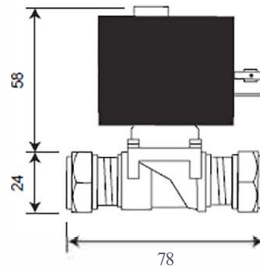

ORDER CODE
15mm 6v G202 Valve

TECHNICAL DATA

Material ABS/Brass
O-ring/washers..... Nitrile
Pressure rating 0.75 Bar – 10 Bar
Orifice 12.7mm
Connection 15mm compression
Voltage 6vDC
Operation type Latching

For battery powered kits Optional low pressure (LP) 0 Bar – 1.5 Bar maximum

6v (4mm orifice) solenoid valve for battery powered kits.

You will need to provide length of 2 core cable from valve to control box.

ORDER CODE
15mm 6v (4mm) Valve

TECHNICAL DATA

Material ABS/Brass
O-ring/washers..... Nitrile
Pressure rating 0 Bar – 1.5 Bar max.
Orifice 4mm
Connection 15mm compression
Voltage 6vDC
Operation type Latching

For battery powered kits Optional very low pressure (VLP) 0 Bar – 0.5 Bar maximum

6v (6.7mm orifice) solenoid valve for battery powered kits.

You will need to provide length of 2 core cable from valve to control box.

ORDER CODE
15mm 6v (6.7mm) Valve

TECHNICAL DATA

Material ABS/Brass
O-ring/washers..... Nitrile
Pressure rating 0 Bar – 0.5 Bar max.
Orifice 6.7mm
Connection 15mm compression
Voltage 6vDC
Operation type Latching



ROBERT PEARSON & COMPANY LTD

Post Office House, Post Office Lane
Stockton, Warminster
Wiltshire BA12 0SE

Telephone: (01985) 850954
Facsimile: (01985) 850112

E-Mail: sales@robertpearson.co.uk
Website: www.robertpearson.co.uk